



Key Features

Navigator-controlled, variable speed chain hoist with a five-pocket lift wheel for fast, quiet, and precise lifting movements.

Complies with the highest levels of hoist safety standards, including BGV-D8, BGV-D8+, and BGV-C1.

Fitted with a load cell for overload and underload monitoring; and with independent dual brakes to achieve a maximum safety factor of 10:1 (BGV-D8+ and BGV-C1 configurations only).

Top and bottom limits as well as two ultimate limits to set the highest and lowest lift positions.

Complies with UL, CE, and CSA standards for industrial equipment.

Description

The TAIT Nav-Hoist is a fully automated and integrated electric chain hoist that meets the highest level of hoist safety (BGV-C1). A single Nav-Hoist can be configured for use in different theatrical and staging operations; as a single-fall or double-fall setup and inverted for motor-down operation.

The Nav-Hoist features variable speed operation, dual independent brakes, and a five-pocket lift wheel for fast, quiet, and smooth lifting. The Nav-Hoist, as part of the TAIT Navigator system, can perform intricate and precise movements, while maintaining complete control over the load.

Dimensions

NAV-Hoist – Suspension Hook

ISO View

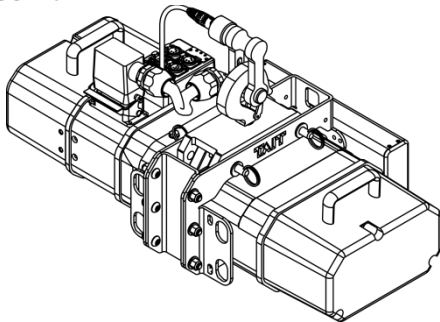

Top View

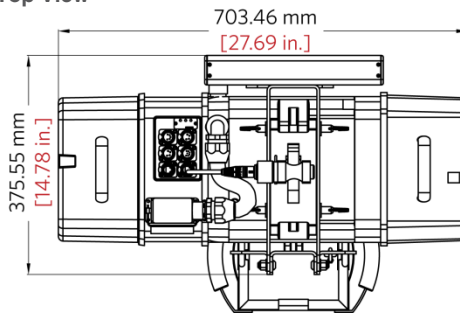

Side View

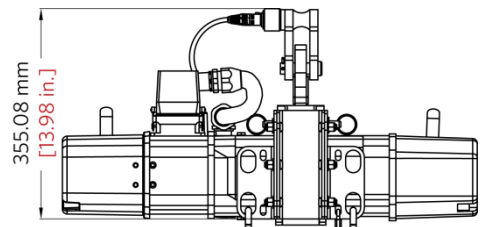

Nav-Hoist – Single-hole Suspension Eye

ISO View

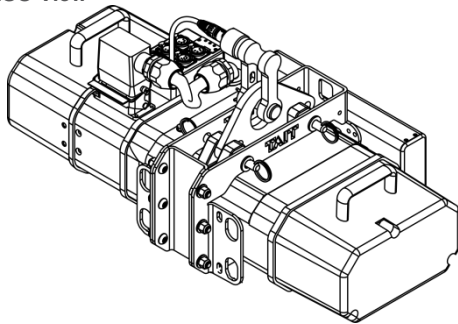

Top View

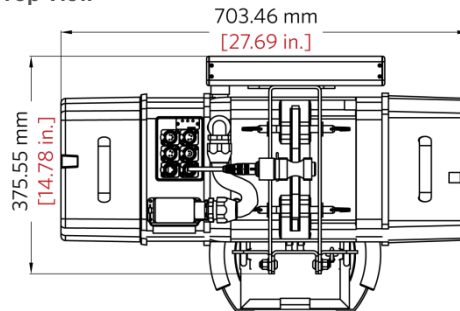

Side View

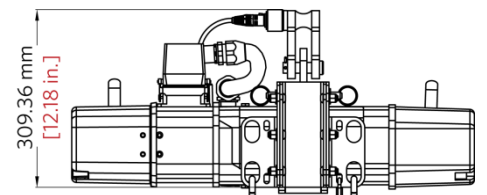

Specifications

Electrical		
Motor Phase	3 Phase + PE	
Duty Cycle	25%	
Rated Voltage	200–240 VAC, 50/60 Hz	
Power	2.6 kW	
Current	9.7 A at 208 VAC, typical	
Full Load Amps (FLA)	15 A (panel)	
Connections		
Power	5-pole, L21-30 cable (3 phase + 1 ground + 1 neutral)	
Control	4-pin XLR + 7-pin XLR	
Network	Ethernet	
Network Switch Port	Two (2) Ethernet, built-in	
Load Cell Ports	Two (2), 5-pin XLR cables (4-20 mA with 24 VDC supply)	
Encoder	Incremental HTL Encoder or SSI Absolute Encoder (depending on model)	
Mechanical		
	Falls Capacity	Speed
BGV-D8	1 500 kg (1102.31 lbs)	2.4 to 25 m/min (8 to 84 ft/min)
BGV-D8+	1 250.0 kg (551.16 lbs)	2.4 to 25 m/min (8 to 84 ft/min)
	2 500 kg (1102.31 lbs)	0.3 to 12 m/min (1 to 42 ft/min)
BGV-C1	1 250.0 kg (551.16 lbs)	2.4 to 25 m/min (8 to 84 ft/min)
	2 500 kg (1102.31 lbs)	0.3 to 12 m/min (1 to 42 ft/min)
Length of Lift, standard	22.86 m (75.0 ft)	
Max. Length of Lift, achievable	Standard Limit Box (280 nominal rotations) Single-fall: 56.0 m (187.0 ft) Double-fall: 28.35 m (93.0 ft) High-rotation Limit Box (470 nominal rotations), optional Single-fall: 87.78 m (288.0 ft) Double-fall: 43.89 m (144.0 ft)	

Environmental	
Operating Temp	40.0° C (104.0° F)
Enclosure Rating	Type 1
Hoist Standard	BGV-D8, BGV-D8+, BGV-C1
Construction	
Dimensions (L x W x H)	With Suspension Hook: 703.46 mm x 375.55 mm x 355.08 mm (27.69 in. x 14.78 in. x 13.98 in.) With Single-hole Suspension Eye: 703.46 mm x 375.55 mm x 309.36 mm (27.69 in. x 14.78 in. x 12.18 in.)
Weight	51.38 kg (113.27 lbs)
Certifications	
Safety	Conforms to UL 508 Complies with CE standards Certified to CSA 22.2 No. 14
Hoist Standard	BGV-C1
Accessories	
Chain	Type: RUD EN 818-7 DAT Size: 7 x 22 mm Weight: 0.74 kg/m (0.50 lbs/ft)
Load Cell	Type: Double-strain dog bone Load Capacity: 2948.35 kg (6500.0 lbs) Current Rating: 4–20 mA (3-wire) Input Voltage: 14–40 VDC Precision: ±2% FSO Operating Temp: –46° C to 121° C (–50° F to 250° F) Compensated Temp: 15° C to 71° C (60° F to 160° F) Safety Factor: 10:1 @ 2 Tons

Packaging and Shipping

Number of units per Dolly	One (1)
Stacking	One (1) dolly can be stacked on top of another
Dimensions (L x W x H)	812.80 mm x 571.50 mm x 714.38 mm (32.0 in. x 22.50 in. x 28.13 in.)

Packaging Weight	
Dolly only	56.25 kg (124.0 lbs)
Dolly with unit	107.62 kg (237.27 lbs)

ISO View

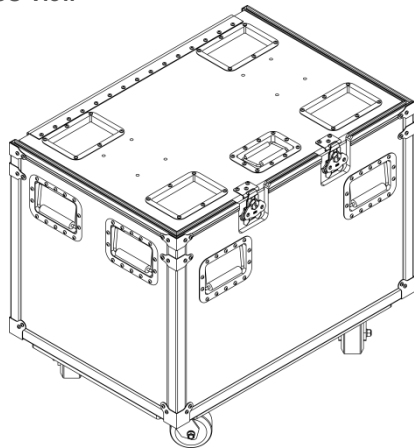

Front View

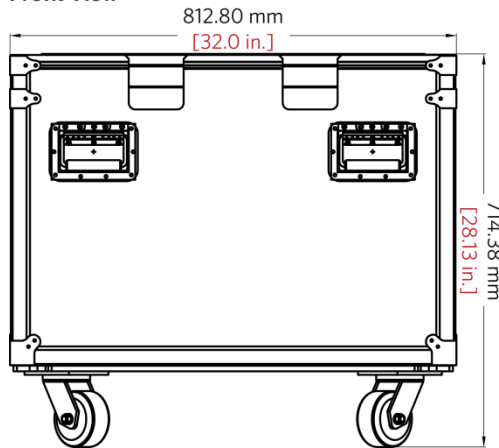

Side View

